Guideline on Selection and Installation of Point Of Use (POU) Drinking Water Treatment Technologies at School Level

**Submitted to:
USAID-HIP/UNICEF**

**Submitted by:
Environment and Public Health Organization
(ENPHO)**

2008

Table of Contents

1.	Introduction	1
1.1.	Background	1
1.2.	Objective	2
1.3.	Target audience	2
2.	Steps towards installation of POU options at schools	2
2.1.	Assesment of Schools	4
2.2.	School-appropriate water treatment technologies	5
a)	Colloidal Silver Filter (CSF)	6
b)	Large Colloidal Silver Filter (Large CSF)	6
c)	Biosand Filter (BSF)	7
d)	Solar Water Disinfection (SODIS)	8
e)	Chlorination	8
2.3.	Selection of appropriate POU technologies.....	9
3.	Specifications and Installation guide	12
3.1.	Colloidal Silver Filter (CSF)	12
3.2.	Biosand Filter (BSF)	18
3.3.	Solar Water Disinfection (SODIS)	23
3.4.	Chlorination	26
4.	Operation and Maintenance.....	28
4.1.	O&M of CSF	28
4.2.	O&M of Large CSF:	30
4.3.	O&M of BSF:.....	31
4.4.	O&M of SODIS:.....	32
4.5.	O&M of Chlorination:.....	33
4.6.	O&M requirements:.....	34

ANNEX

ANNEX: 1 Initial assessment form

ANNEX: 2 Monitoring checklist

1. Introduction

1.1. Background

According to the World Health Organization (WHO), access to safe drinking water can reduce cases of diarrheal diseases by 39 percent. While governments and civil societies must prioritize and budget for improved access to safe drinking water at home, school, work and market place, there is extensive evidence which demonstrates that even in the absence of clean water at source, treating water at the point-of-use is an effective way to assure safe drinking water at scale. Even when quality water is available at source, there is a role for proper handling and treatment to assure consumption of safe drinking water. Nepal has been in the vanguard of public and private initiatives and partnerships to increase both supply of and demand for point-of-use water treatment products. So far, these efforts are mainly focused at household level and very little attention has been given to improve drinking water quality at the institutional level, particularly in schools.

Promotion of point-of-use water technologies in schools not only provides school children, a vulnerable audience, with safe drinking water to reduce diarrheal disease, and increase and enhance school performance; in addition, school children can help increase use of POU technologies in their communities and homes through school-to-community activities, so are important agents of change.

The POU drinking water treatment pilot project being implemented by Department of Water Supply and Sewerage (DWSS) with support from USAID/HIP and UNICEF is working towards improving access to safe drinking water for school students in 200 schools of four districts (Dang, Kapilvastu, Parsa and Panchttar) through use of point-of-use water treatment technologies such as filtration, chlorination and solar water disinfection (SODIS).

Before installing or promoting POU drinking water treatment technologies in schools on a large scale, the project set out to conduct effectiveness studies to see if these technologies that are proven efficacious in a laboratory can be carried out successfully by school officials and students. The project also committed to developing guidance for users regard the most appropriate technologies in different school contexts, installation instructions and on effective elements and mechanisms for maintaining treatment technologies given existing school resources and users perceptions.

This programming guideline has been prepared based on operations research conducted by ENPHO/SOLUTIONS team under the USAID/HIP-UNICEF POU drinking water project in 12 schools of Dang and Kapilvastu district.

1.2. Objective

The main objective of this guideline is to provide guidance to programme implementers/agencies, school management committee for installation, operation & maintenance of appropriate POU technologies in schools of Nepal.

The specific objectives are to provide:

- basic assessment and selection criteria for “point-of-use”-ready schools.
- technical details of appropriate School POU technologies with installation procedure, cost estimation & design
- selection criteria for identifying appropriate POU drinking water treatment technologies in different contexts;
- guidance on operation and maintenance (O&M) requirements, and mechanisms for sustainable maintenance using existing resources.

1.3. Target audience

This guideline can be used as a reference document for the installation, Operation & Maintenance and monitoring of POU technologies at school level by programme managers/implementers, technicians and technology promoters. The cost estimate and design of technologies mentioned in this document are very general and can vary with respect to school contribution and school environment and availability of materials at local level.

2. Steps towards installation of POU options at schools

Promoting water treatment in schools requires the collaboration of a range of stakeholders in the planning, installation, and maintenance of water treatment options. Planning activities can be more or less participatory. If done well, increased participation via committees or consensus usually means a stronger, longer lasting commitment to maintenance, protection, and use. POU promoters can work through existing committees such as school management committees, child clubs; or a new committee can be formed.

Care must be taken to not overburden volunteers with extensive tasks or lengthy planning discussions, as their time is limited, and their enthusiasm can be dampened with extensive and/or intensive planning sessions. Community participation must not exclude technical expertise, when making decisions about water treatment technologies.

The steps for introducing POU Water Treatment in Schools include:

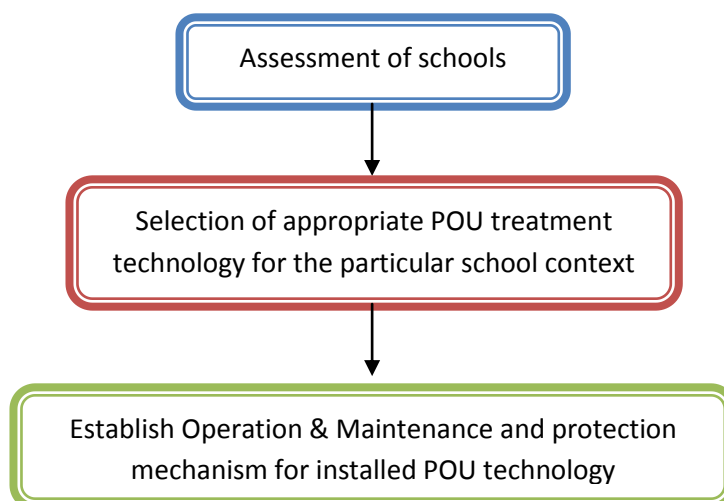

During each above mentioned steps, there should be involvement or participation of stakeholders such as school management committee, school teachers, child club members, school staffs (peon or caretaker), and parent teachers associations. Key roles and responsibilities of each stakeholder during the steps for introducing POU water treatment in schools are presented below in the table:

SN	Key stakeholders	Responsibilities
1.	School management committee	<ul style="list-style-type: none"> • Provide sufficient information during assessment survey; • Involve in decision making process during the selection of appropriate POU technology for school; • Decide and manage school contribution for installation of POU technology; • Delegate a staff for day to day O&M of installed system; • Periodic monitoring and supervision of installed system;
2.	School teachers	<ul style="list-style-type: none"> • Support school management committee during decision making process; • Regular monitoring and supervision of installed system; • Inspect to ensure if all students are drinking treated water from installed technology or not; • Provide orientation to students on safe water, good hygiene and sanitation as per requirement;
3.	Child club members or assigned school students	<ul style="list-style-type: none"> • Involve in day to day operation of installed POU technology particularly for CS filters. For e.g. pouring water into the filter; • Report to school teacher or care taker in case of any operation and maintenance problems; • Assist school teachers to monitor if all students are drinking treated water from installed technology or not;

4.	Peon or care taker	<ul style="list-style-type: none"> • Regular monitoring of POU technology to ensure continuous operation of the technology; • Maintain installed technology and fix the O&M related problems; • In case of Biosand Filter, perform regular O&M of the filter;
5.	Parent teachers association	<ul style="list-style-type: none"> • Involve and support school management committee during decision making process; • Periodic monitoring and supervision of installed POU technology; • Assist school management committee to seek funds as school contribution if need

2.1. of Schools

Assessment of school is the first step before installation of POU technologies. It is very important to select appropriate schools which show genuine commitment towards providing safe water and can properly operate and maintain the system in the long run. Several factors could support in deciding a technology for particular school. An initial assessment should be done of potential schools by visiting the school and interviewing school management committee or the school principal. A structured questionnaire form for initial assessment survey has been provided in Annex: 1, which can be used for this purpose. Following are the key factors for selecting school for installing POU water treatment system:

Process/Factors	Description
a) Assessment of water quantity, accessibility and reliability	The assessment should be made on the quantity of water supplied by the source; access to the source; and reliability of the source for long term use. Based on the assessment, water sources having sufficient and reliable supply of water which is also relatively easy to fetch should be selected.
b) Water Quality testing of drinking water sources	The water quality test results helps to give a better idea on the appropriate technology needed for a particular school. Water could be tested using a field test kit which gives a semi quantitative result or through laboratory process if an accredited laboratory is located nearby and school/ project has some funds to do so. The school/project could also seek support from the local water supply office to know the quality of water in this case. Some of the basic parameters that needs to be tested in this process is the available fecal contamination, turbidity and in case of ground water, possible iron and arsenic content. If the school area/ community is affected with any other kind of water quality problem such as calcium

	incrustation then this should also be considered in this process.
c) Availability of space for installing water treatment technology	Schools should have enough space for installing water treatment device. Availability of space close to the water source would be appropriate for easy operation and maintenance of the system. In some cases school may not have appropriate space for such provision. A consultation with the school management committee should be done to make arrangement for an appropriate space to install POU technology. It could be inside class rooms, school office room or nearby classroom as appropriate.
d) Appraisal of felt need by school, interest in cooperation and contribution of school management for installation of water treatment technology	Interest of school management committee and staff towards installation of water treatment system would highly influence the sustainability of the system. Level of contribution provided by the schools can be one of the ways to assess the commitment of the school and can be a selection criterion. This commitment could be in the form of cash or kind such as raw materials/accessories, human resource.
e) Distance and accessibility	Distance and accessibility of the school should be taken into consideration to plan on the supply of raw materials, mode of transportation, together with overall planning on the installation process.
f) Availability of	Installation of POU technologies particularly Biosand filter will require recommended quality and quantity of filter media such as sand, gravel and coarse sand. This could be expensive if it is transported from far off places. Thus, if available and y.
g) t	While assessing the possible area for placement of drinking water treatment option, one should also consider safe and secure location to avoid theft and damage to the system. If the school premise does not have proper protection walls and gates for security and if there are chances of theft, then the option should be placed in a secure place and this could also be a classroom or teacher's room or any common room of the school.

2.2. School-appropriate water treatment technologies

Once the school has been assessed and information is collected following the above process, it is now appropriate to discuss and decide on particular technology as per the need of the school. Several technologies have been identified as the school appropriate water treatment technologies and according to the condition of water (quantity and quality), physical assessment and from the discussion with the school management committee, this technology should be decided. Following are five school appropriate water treatment technology that could be used by schools namely:

Colloidal Silver Filter (CSF), Large (High Volume) Colloidal Silver Filter (Large CSF), Biosand Filter (BSF), Solar Water Disinfection (SODIS) and Chlorination. These technologies have been tested in the schools for its effectiveness in the school condition and have been modified according to the research outcomes. Each of these has been discussed below with summary matrix at the end of this section that provides easy reference for comparing the basic features and requirements of each method:

a) Colloidal Silver Filter (CSF)

Colloidal Silver Filter (CSF) is a clay filter with impregnation of colloidal silver to kill harmful pathogenic bacteria in drinking water that cause various waterborne diseases. The filter containers are made of clay or plastic with collection capacity of 5-8L. The design filtration capacity of such CSF is 2-3 L/hr. This filter has been designed mainly for the household use. However, in schools a series of CSF can be placed at secure, convenient centralized location or some numbers of filters per class. The required number of filters can be calculated based on number of users (school students and staff).



Advantages	Limitations
Low cost technology	Fragile
Simple installation and O&M procedures	Low flow rate
Portable	Quick clogging if water is turbid and contains high iron content

Cost:

- SBL clay CS filter – NRs. 300-400
- “SAFA” plastic CS filter – NRs. 700-800

b) Large Colloidal Silver Filter (Large CSF)

A larger version of the CSF can be made by using 100 L plastic tanks for filtration and collection units. The filtration unit of large CSF consists of three colloidal silver treated filter candles that filter water. This filter has a capacity to treat 10 - 15 liters of water per hour.

Advantages	Limitations
Low cost technology	Need water pump and electricity to pump water
Simple installation and O&M procedures	Quick clogging if water is turbid and contains high iron content
Good flow rate	

Cost: NRs. 8000-9000

c) Biosand Filter (BSF)

Biosand filter is designed to remove turbidity, iron and microbial contamination from drinking water. It has layers of gravel and fine sand on top of which a biological layer develops that helps in removing pathogenic bacteria from water. The household level BSF, which can treat 15L of water per hour, can be modified to treat larger quantities of water. Biosand filters with 200, 300, 500 and 1000L tanks have been developed and used to obtain larger quantity of treated water. Provided this capacity and availability of raw materials like sand and gravel, it could easily address the water demand of schools. Previous studies revealed that the filter can remove up to 95% bacteria, 99% turbidity and 95% iron. This filter can also effectively remove arsenic by adding 5 kg iron nails in the diffuser basin. Biosand filter designed for arsenic removal is known as Kanchan Arsenic Filter.



Advantages	Limitations
Can remove pathogens, iron, turbidity and arsenic from drinking water	Expensive
Simple O&M procedures	Require trained technician to install
Good flow rate	Need water pump and electricity to pump water

Cost:

- NRs. 15,000-18,000 (without stand)
- NRs. 22,000-25,000 (with stand)

d) Solar Water Disinfection (SODIS)

Solar water disinfection is a very simple, low cost and efficient technology for drinking water disinfection at household level and for small user groups. SODIS uses solar energy to destroy pathogenic microorganisms causing water borne diseases. Pathogenic microorganisms are vulnerable to two effects of sun light: radiation of UV rays and heat produced due to increased temperature. SODIS is ideal for disinfecting small quantities of water. In this method, less turbid or filtered raw water is filled in PET (Poly Ethylene Terephthalate) bottles of 1 to 2 L capacity and exposed in sun for a day (about 6 to 7 hours) or 2 days on cloudy days. After the complete exposure water is ready for drinking.



Advantages	Limitations
Simple, low cost technology	Efficiency depends upon climatic conditions
No change in taste and smell after doing SODIS	Not effective if water is too turbid (>30 NTU)
As bottles are reused, it helps in waste management	PET bottles may not available everywhere

Cost: Bottle cost – NRs. 11 per new bottle

e) Chlorination

Chlorination is one of the most convenient, effective and a low cost method for disinfection of drinking water. Chlorine-based chemicals can prevent microbial re-growth and help protect treated water throughout the supply system, long after the treatment process. Commercially available forms of chlorine, such as chlorine gas, sodium hypochlorite solution, calcium hypochlorite or bleaching powder is often used for treating large volumes of water. These products can be found in market in bulk amount and some chlorine solutions, such as PIYUSH and Water guard, are also available in small scale to treat drinking water at the point of use.

When chlorine is added to water following chemical reaction occurs:



Thus, formed hypochlorous acid kills microorganisms, oxidizes organic constituents, removes color from water and also destroys chloramines produced due to reaction of ammonia in water. An adequate dose of chlorine is required to achieve complete destruction of microorganisms. Sufficient chlorine should be added in order to achieve residual chlorine to ensure complete disinfection and to prevent recontamination. As it takes about half an hour to achieve complete

destruction of microorganisms, the water becomes suitable for drinking after half an hour following chlorination.

Advantages	Limitations
Simple and low cost method of water treatment	Peculiar smell of chlorine after chlorination
Can treat larger quantity of water	Not effective in turbid water (> 5 NTU)
	Need to wait for 30 minutes after adding chlorine solution

Cost:

- Cost for the materials such as chlorine solution, bleaching powder approximately NRs. 40 to treat 1000 L water.

2.3. Selection of appropriate POU technologies

After the selection of school, the next step is to determine an appropriate POU technology with regard to school condition and support potential. POU technologies most appropriate for the school setting, based on research, include:

1. Colloidal Silver Filter (CSF):
 - a. Regular CSF:
 - i. SBL CS filter
 - ii. "SAFA" Plastic CS filter
 - b. Large CSF
2. Biosand Filter (BSF):
 - a. BSF with 300 L and 500 L capacity
 - b. BSF with iron nails for arsenic removal
3. Solar Water Disinfection (SODIS)
4. Chlorination

Before installation of any technology, it is very important to establish which POU technology is appropriate for which school. Some of the crucial factors/criteria for selecting POU technologies are presented below in table 1. School participation during the selection and decision making processes is also very important. School management committee, staff and students should be aware of why POU technology is needed for the school and which technology is appropriate for the school. After selection of POU technology, orientation should be provided to the school on drinking water quality & health and various POU technologies with the particular focus on the technology that is being provided to the school.

Table 1 for selection of POU technologies:

Criteria for selection of POU technologies		Decentralized system		Centralized system/method			
		Regular CSF	Large CSF (100 L)	BSF (300 L)	BSF (500L)	SODIS	Chlorination
General	School location	Access to road for filter supply	Access to road for filter supply	Access to road for filter and materials supply	Access to road for filter and materials supply	Easy availability of PET bottles	Easy availability supply of chlorine solution or bleaching powder
	No. of students served per unit per day <i>(determined by flow rate of POU technologies)</i>	12	60	400	1200	Depends upon no. of bottles available	Depends upon the size of the tank
	Existing facilities	Regular water source	Regular water source & electricity	Regular water source & electricity	Regular water source & electricity	Regular water source	Regular water source, electricity and tank
Technical	Flow rate (L/hr.)	2-3	10-15	80-100	250-300	Number of bottles	Tank size
	Max. iron level (ppm)	<0.3	<0.3	<10	<20	<0.3	<0.3
	Max. turbidity level (NTU)	<5	<5	<50	<100	<5	<5
	Max. Arsenic level (ppb)	<10	<10	<500 (with 5 kg. of iron nails)	<500 (with 5 kg. of iron nails)	<10	< 10

Guideline on Selection, Installation and Promotion of POU Technologies at Schools

	Factors/Criteria for selection of POU technologies	Regular CSF	Large CSF (100L)	BSF (300 L)	BSF (500L)	SODIS	Chlorination
	Who can install?	Trained person or school staff	Trained plumber or technician	Trained plumber or technician	Trained plumber or technician	Trained person or school staff	Trained person or school staff
Others	Where to install?	Inside classrooms with enough space, secure door & windows	Inside classrooms with enough space, secure door & windows	Centralize near water source if have secure boundary	Centralize near water source if have secure boundary	Clean roof or stand	Clean water tank
	Type of stand and additional materials	Strong stand or base	Strong stand or base	Strong stand or base, shed to keep water cool	Strong stand or base, shed to keep water cool	Properly cleaned bottle; secure place to prevent from possible recontamination during the exposure	Correct calculation of volume of tank, water and chlorine solution

3. Specifications Installation

This section provides specifications, design, materials required including installation guide of each POU technology. In order to install regular CSF and adopt SODIS & chlorination method at school don't require people with technical background. After receiving an orientation, school teachers, secondary level students and peon or caretaker can easily manage to install CSF and adopt SODIS & chlorination method. Whereas, for installing Large CSF and Biosand filter trained plumber or technician is required and should receive proper hands on training on filter installation. This has been mentioned in above section at Table 1. So, it is not recommended that any guideline users should try to install large CSF and Biosand filter without receiving proper installation training from specialized agency or person.

3.1. Colloidal Silver Filter (CSF)

3.1.1. Regular CSF

3.1.1.1. SBL CS Filter

a) Specifications

SBL CS Filter consists of two sections – upper section with circular ceramic silver treated disc and lower portion for collection of treated water. It can be manufactured locally by trained potters.

Materials required:

SN	Materials
1.	Filter set
2.	Filter stand

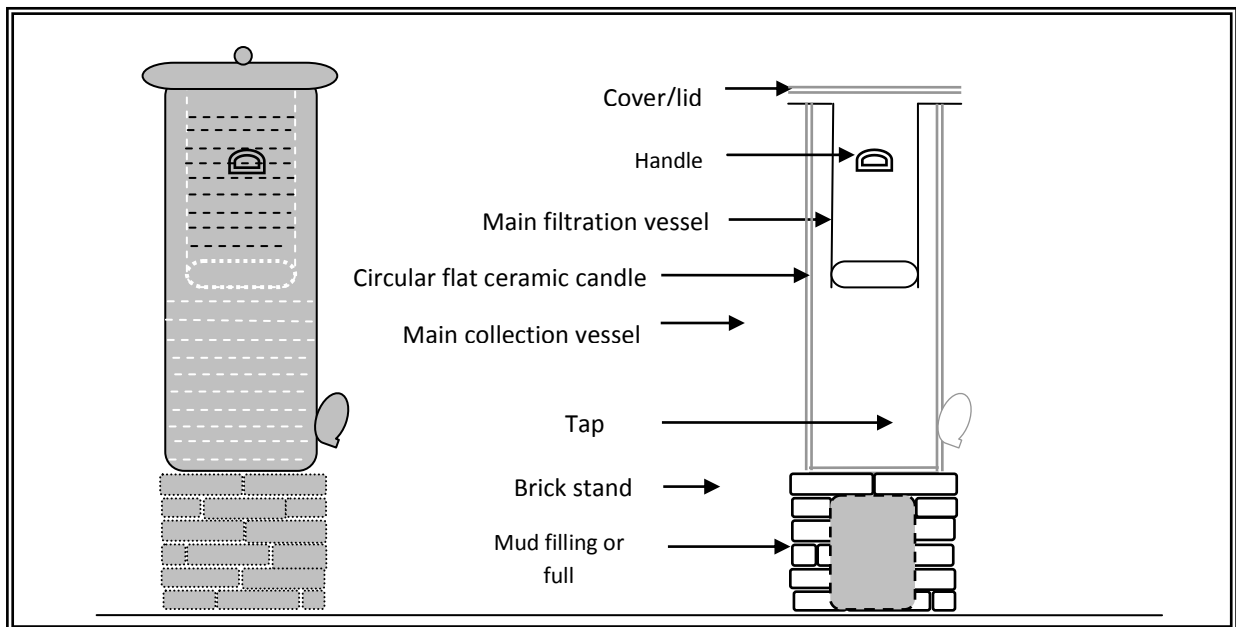
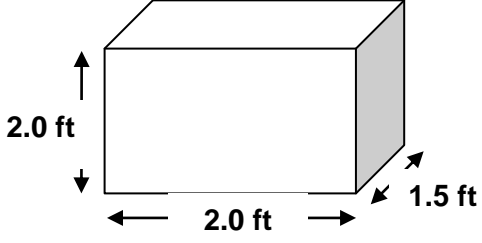

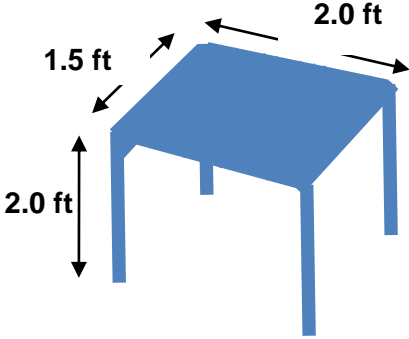



Figure 1 Layout of regular CSF

Specifications of stand:

Description	Specifications	Photo
Brick stand		
Metal or wooden stand		

b) Installation procedures

1. Identify secure location to make a stable brick, metal or wooden stand of 2' height. If it is not possible to build a stand then the filter can be placed on robust & stable chair. Filter should be kept away from direct sun exposure.
2. Make sure the stand is set up before placing the filter on it;
3. Clean the filter set thoroughly. Pour water into the filter for checking the cracks. If cracks are observed replace with new filter;
4. Place the filter on the stand. Remove a lid and slowly pour water to upper container;
5. Then filtered water will be collected at the lower container which is safe for drinking.

3.1.1.2. “SAFA” Plastic CS Filter

a) Specifications

“SAFA” Plastic Filter consists of two container – upper portion with silver treated candle (filtration unit) and lower portion for collection of treated water. The local manufacture- “Thapa mold & dyes Pvt. Ltd” has been producing and promoting this filter in Nepal.

Materials required:

SN	Materials
1.	Filter set
2.	Filter stand

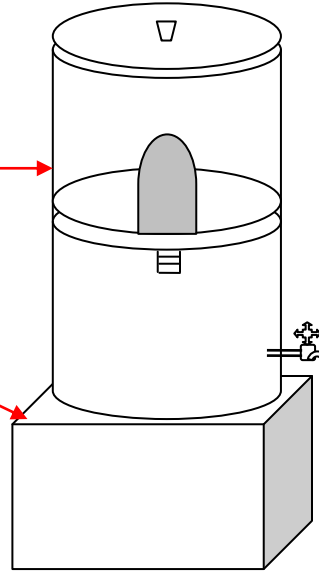



Figure 2 Layout of SAFA plastic CS filter

Specifications of stand:

Description	Specifications	Photo
Brick/metal/wooden stand		

Pictures of installed SAFA filters with various types of stand	
	
Rows of SAFA filters with wooden stand	SAFA filter inside classroom with lock system

b) Installation procedures

1. Identify secure location to make a stable brick, metal or wooden stand of 2' height. If it is not possible to build a stand then the filter can be placed on robust & stable chair. Filter should be kept away from direct sun exposure.
2. Fix the CS candles in the upper container and securely fasten the tap in the lower container;
3. Wash the filter containers thoroughly to remove dust and debris;
4. Make sure the stand is set up before placing the filter on it;
5. Place the filter on the stand. Remove a lid and slowly pour water to upper container;
6. Then filtered water will be collected at the lower container which is safe for drinking.

3.1.2. Large CSF

a) Specifications

Large CSF consists of a 100 L plastic container. A 17 L bucket is placed at the top container that consists of three silver treated candle rods. Then diffuser basin is placed at the bucket

Materials required:

SN	Materials
1.	One 100 L plastic tank (11.5" diameter)
2.	One leakage protection rim
3.	One perforated diffuser basin with lid
3.	One 17 L bucket
4.	Three colloidal treated candles
5.	One Tap with fittings
6.	Brick/Metal/Wooden filter stand

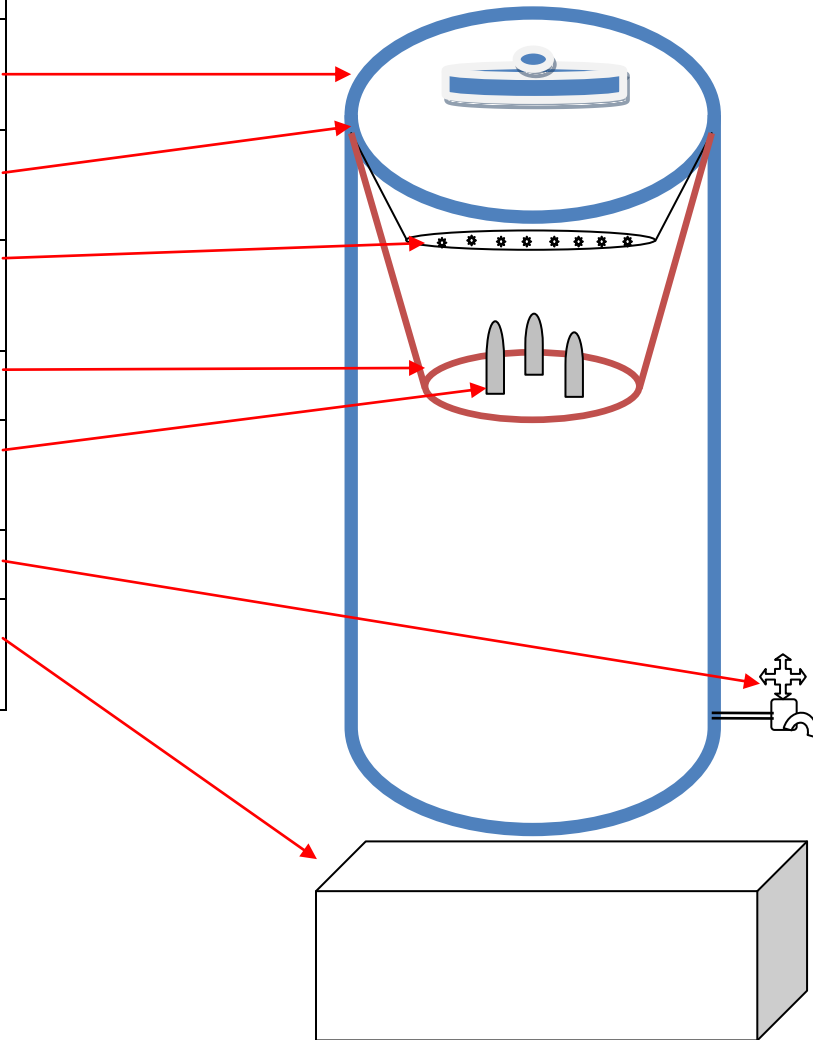
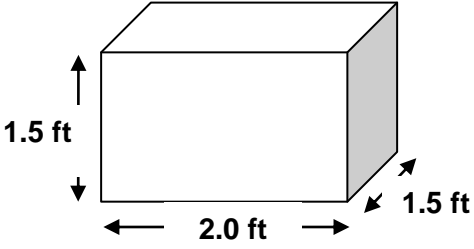





Figure 3 Layout of Large CSF

Description	Specifications
Leakage protection rim	Inner diameter – 12” Outer diameter – 13.5” Height – 1.5”
Diffuser basin	About 65 holes with 0.5 cm dia.
Bucket with CS candles	17 L capacity bucket with three holes of 0.5” dia.

Specifications of stand:

Description	Specification	Photos
Metal or wooden stand		
Brick or concrete stand		
Pictures of various types of stands for large CSF		
		

b) Installation Procedures

1. Construct stand for placing the filter;
2. Clean the tank (100 L) thoroughly and fix the tap;
3. Fix three candles securely in the base of 17 L bucket – this is filtration unit;
4. Make 65 holes with 0.5” diameter in the basin – this is diffuser basin;
5. Prepare a leakage protection rim according to the above mentioned specifications;
6. Place the leakage protection rim onto the opening of tank;
7. Place the bucket with three candles onto the rim and then place the diffuser basin on the top of the bucket;
8. Slowly pour water into the diffuser basin. Immediately water will pass through the candles;
9. Filtered water will collected in the lower portion of the tank which is safe for drinking.

3.2. Biosand Filter (BSF)

a) Specifications:

Based on slow sand filtration principal, BSF has been designed as a simple drinking water treatment technology for the removal of pathogens, iron, turbidity and smell. BSF consists of filtration and collection unit. The filtration unit contains layers of fine sand, coarse sand, gravel as filter media and diffuser basin and pipe fittings to control the water flow. The treated water is collected in the collection unit in which taps are fitted onto it. For the arsenic removal, 5 kg of non galvanized iron nails should be placed into the diffuser basin.

Materials required:

SN	Materials	Length	Qty	Remarks
A.	<i>Filtration and storage unit:</i>			
1.	500 L plastic tank	-	2	
2.	17” Perforated plastic basin		1	
B.	<i>Pipe fittings</i>			
3.	1” Nipple	24”	2	
4.	1” Tank nipple		3	
5.	1” Socket		3	
6.	1” Elbow		2	
7.	1” Tee		1	
8.	1” Nipple	3”	1	

9	1" Nipple	6"	2	
10	1" End plug		2	
11	1" Gate valve		1	
12	Thread tape		6	
13	1"*0.5" Reducer		1	
14	0.5" Nipple	12"	2	
15	0.5" Nipple	4"	3	
16	0.5" Tee		2	
17	0.5" Tap		3	
18	0.5" Elbow		2	
19	1" Nipple	6"	1	
20	0.5" Socket		2	
21	Water pump and fittings		1	
C.	<i>Filter Media:</i>			
22	1mm Fine sand		300 L	
23	3-6 mm Coarse sand	6 mm	75 L	
24	6-12 mm Gravel	6 mm	100 L	
25	0.5" Iron nails		5 Kg	If water contains arsenic
26	Bricks		4 Pcs.	If water contains arsenic
27	Chlorine solution (Piyush)		10 Pcs.	
D.	<i>Filter stand and platform:</i>			
26	Bricks	-	2000 Pcs.	
27	Cement	-	6 Bags	
28	Gravel and sand		½ Tractor	
29	Earth filling	-	-	

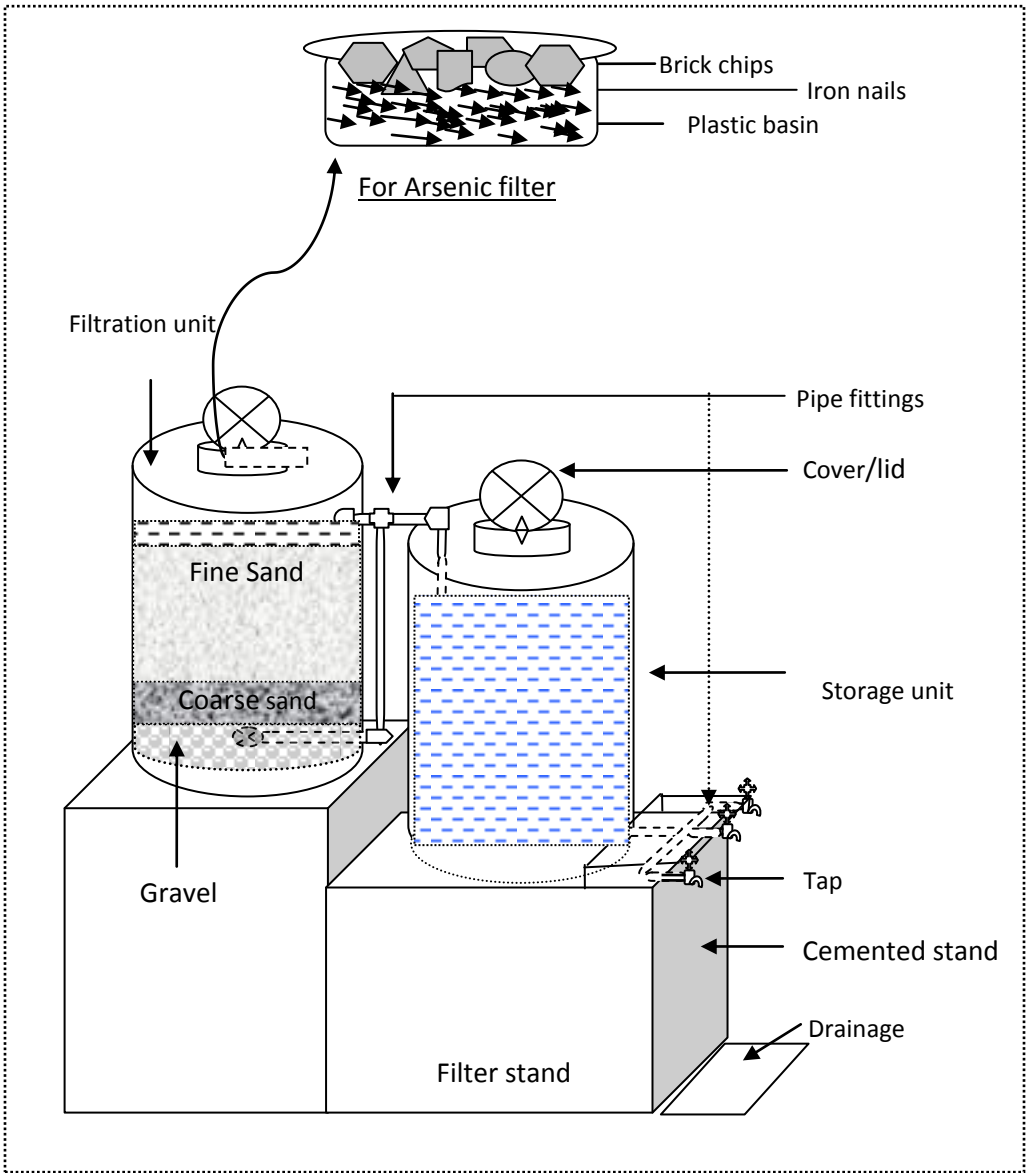

Figure 4 Layout of BSF

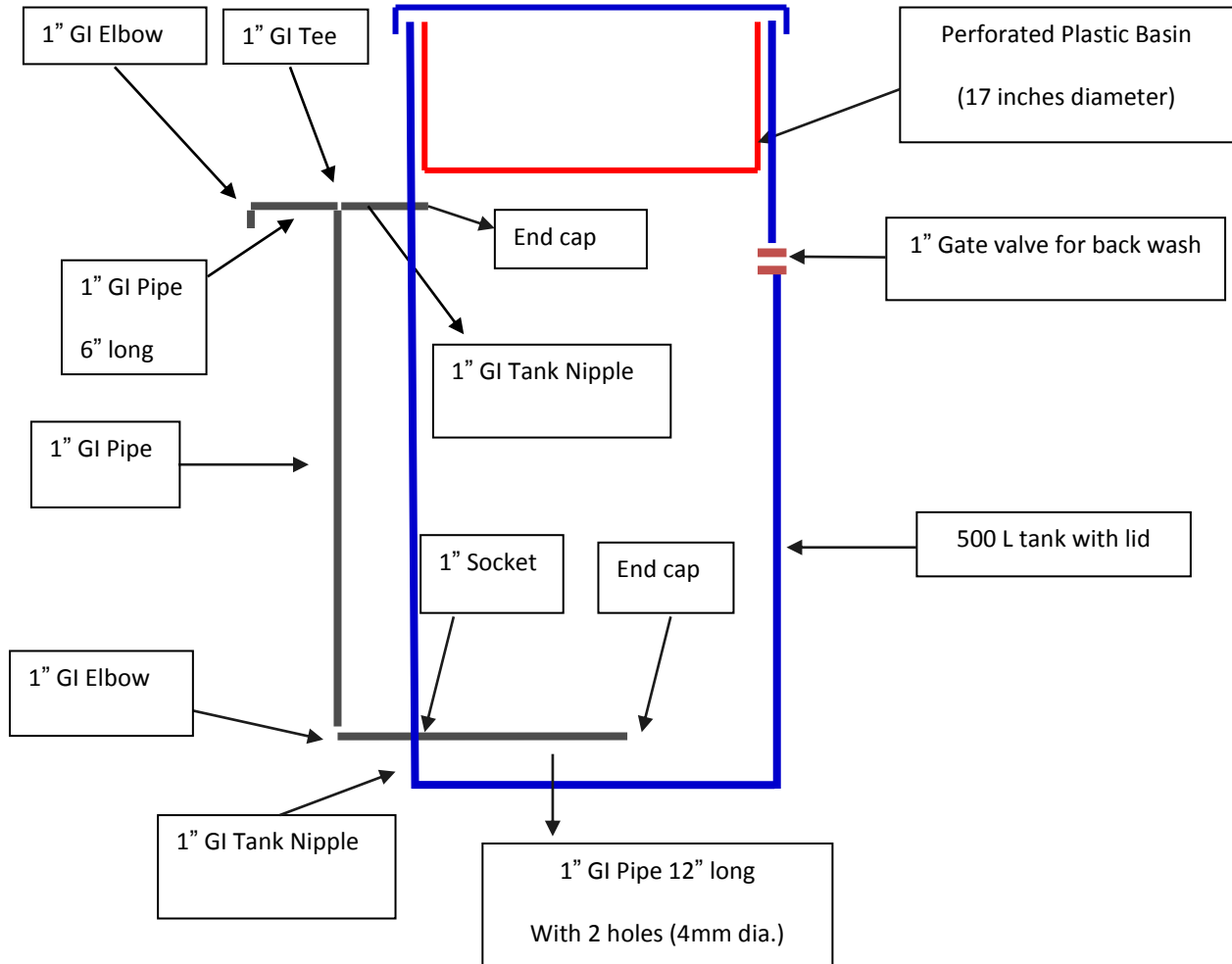
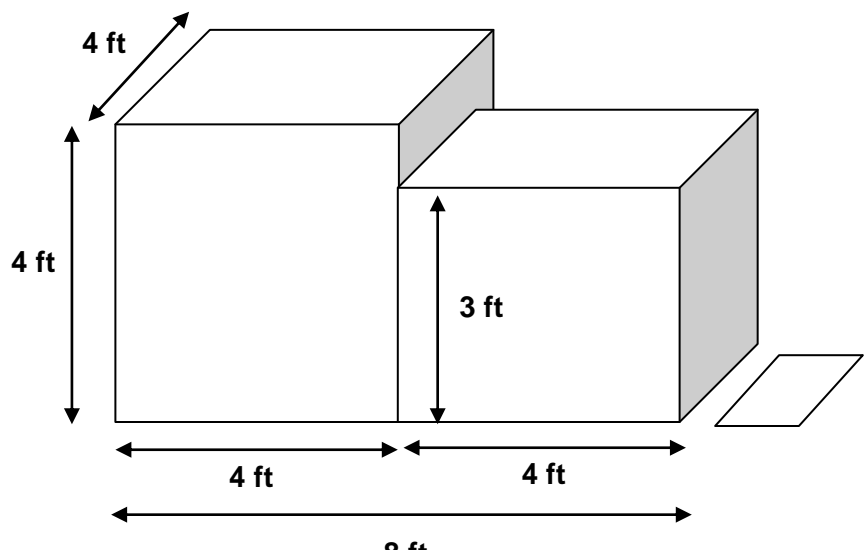

Figure 5 Illustration of BSF container and pipe fittings

Description	Specifications
Stand and platform with PCC and brick work	

Photos of Biosand filters with stand and platform installed at schools



b) Installation Procedures

1. Construct brick masonry stand having dimension of 4 feet in length, breadth and height for placing filtration unit and having length and breadth of 4 feet each and 3 feet in height for placing collection tank;
2. Fix pipe fittings in the filtration unit (see layout 4 for details);
3. Place the filtration unit in the stand;
4. Fill about ½ tank with clean water. Add 10 bottles of Piyush (0.5% chlorine solution); or two and half bottles of WaterGuard (0.72% chlorine solution) to the water. A 600 ml Chlorine solution (0.5% concentration) can be also added in case Piyush and WaterGuard are not available.
5. Slowly add 150 L of cleanly washed gravel and label;
6. Add 100 L of washed coarse sand and label;
7. Add 550 L of cleanly washed fine sand and label;
8. Leave the tank for 12 hour (one whole night) to get the filter media disinfected and set up;
9. Run water through the filter and flush the water until clear water comes out;
10. Place the collection unit in the stand and fix end pipe of the filtration unit on it;
11. Pump water into the filtration unit and clean water will be collected in collection tank;
12. Since it may require 15-20 days (time to develop bio-film) to get optimum pathogens removal, it is recommended to disinfect the filtered water by chlorination or SODIS method.

3.3. Solar Water Disinfection (SODIS)

a) Specification:

Solar water disinfection (SODIS) is simple, zero cost technology for treating drinking water. SODIS requires clean transparent 1 to 2 liters PET bottles with maximum diameter of 10 cm. The bottles should be placed on the clean roof or special stand to prevent outer contamination. In schools, SODIS bottles should be placed in easy accessible location for students. If possible a corrugated sheet stand would give a special space to SODIS practice which works as both treatment and demonstration site.

SODIS steps:

1. Wash the bottle and cap cleanly with soap before use. Take out label if there is any.
2. Fill the bottle fully and close the lid tightly
3. Expose the bottle for about 7-8 hours on sunny days and 2 days during cloudy days
4. The water is safe for drinking

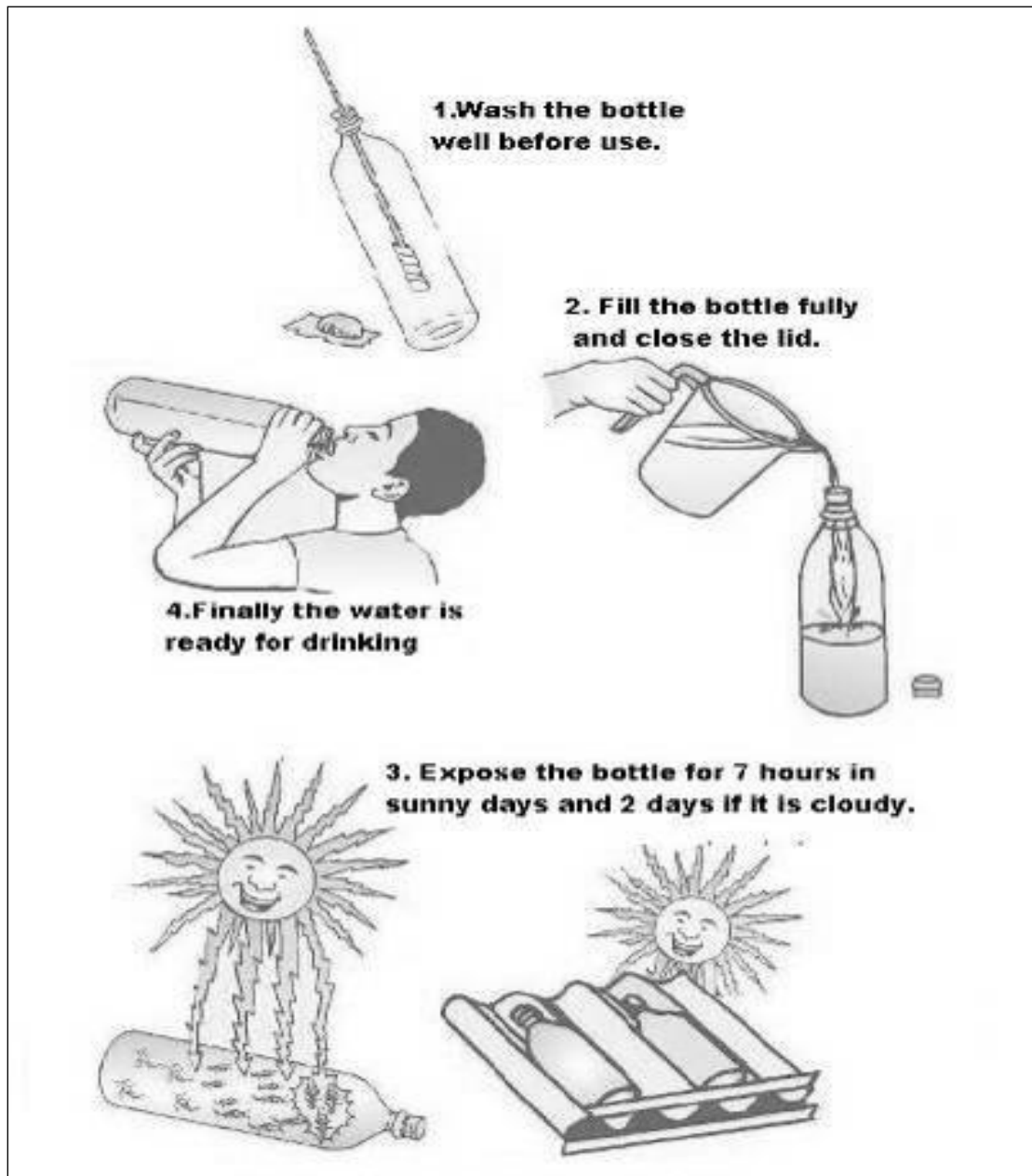
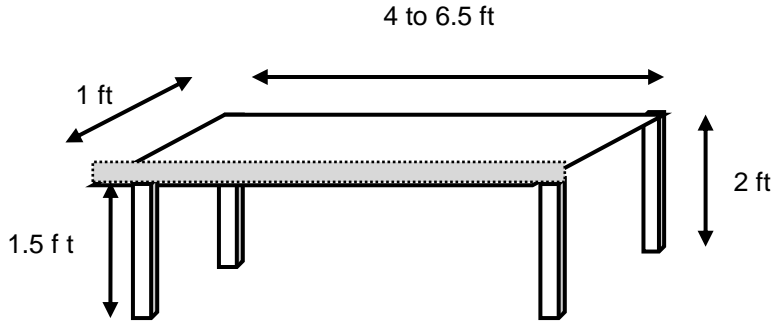

Figure 6 SODIS steps

Materials required:

SN	Materials
1.	Clean bottles
2.	Stand or clean roof

Description	Specifications
SODIS stand made up of metal or wood	

Photos of SODIS method with various types of stand at schools



3.4. Chlorination

a) Specification:

Chlorination is the method of disinfecting water by using chlorine solution. Chlorination can be done at household level as well as institutional level such as schools. To adopt this method at schools, a tank (concrete, plastic or steel) is required. And it is very important to know the correct volume of the water tank so that exact chlorine dosing can be done.

b) Method of using chlorine solution

- Three drops of 1% chlorine solution can treat 1 liter of drinking water
- One liter of chlorine solution can treat 10,000 liters of water.
- After determining the volume of water tank, the exact chlorine dose can be determined. For example: How much chlorine solution is required to treat 2000 liter water?
 - ⇒ For 10,000 liter water – 1 L chlorine solution
 - ⇒ For 1 L water – 1/10,000 L chlorine solution
 - ⇒ **For 2000 L water – 1/10,000 X 2,000 L = 0.2 L or 200 ml chlorine solution is required**
- Drink water after 30 minutes of adding chlorine solution.

c) Calculating water tank volume

- i. For Rectangular water tank:

Volume of tank (V) = [Length (L) x Breadth (B) Height (H) of tank] 1000 L

Example:

Given that L=2 m; B=2 m & H=3 m

$$V = \frac{L \times B \times H}{1000} = \frac{2 \times 2 \times 3}{1000} = 12,000 \text{ L}$$

Therefore, Volume of the tank (V) = 12,000 L

And to treat 12,000 L water – 1/10,000 X 12,000 L = 1.2 L of chlorine solution is required

- ii. For Cylindrical water tank:

**Volume of tank (V) = [πr^2 Height (H) of tank] 1000 L,
Where "r" is radius of the tank (r = diameter/2) & $\pi = 22/7$**

Example:

Given that $r = 1\text{m}$; $H = 3\text{ m}$

$$V = (\pi \times r^2 \times H) \times 1000 \text{ L} = \frac{22}{7} \times 1 \times 1 \times 3 \times 1000 \text{ L}$$

Therefore, Volume of the tank (V) = 9428.5 L

And to treat 12,000 L water – $\frac{1}{10,000} \times 9428.5 \text{ L} = 0.95 \text{ L}$ or 950 ml of chlorine solution is required

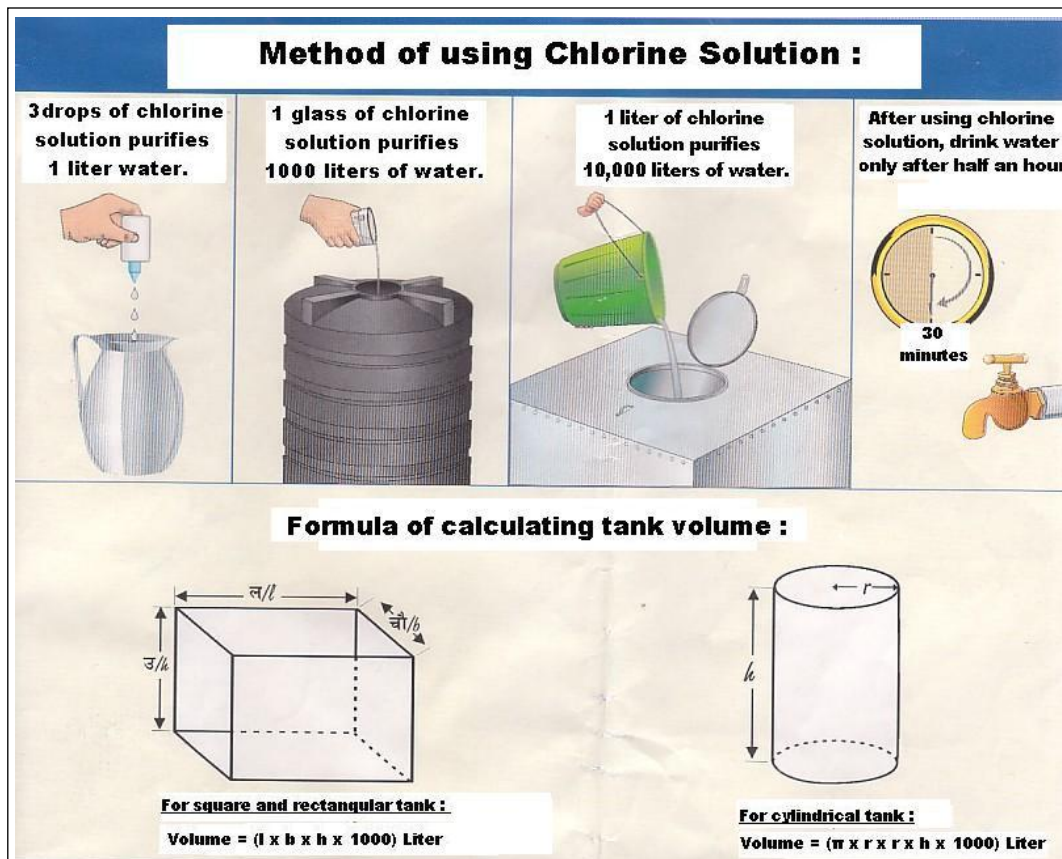

Figure 7 Illustration of method of preparing and using chlorine solution

4. Operation and Maintenance

Proper and sustained operation and maintenance (O&M) procedures will ensure that the installed technologies will be operational for a long time. In selecting a particular method, the group/implementers should have already concluded that the resources for operation and maintenance of this particular method are already available, or can be readily mobilized.

O&M procedures of the installed POU technologies should be clearly explained to school staff (administrative and school teachers) and students (child club members) and they should receive hands on training as well. If the users/consumers don't know and use regular O&M procedures of the system, the installed technologies may become unusable.

The first part of this section describes about O&M procedures of each technology. Later section explains the key O&M requirements and responsible group/person to carry out these requirements.

4.1. O&M of CSF

4.1.1. Operation procedures :

There are two types of CSF viz. SBL CSF and SAFA Plastic CSF. Since SBL CSF is made up of clay, operation should be carefully done to prevent from possible breakage. The filter should be placed at the secure location and also should be easily accessible to users particularly to small school children. Following are the operation procedures of CSF:

- Open the lid from the upper container;
- Slowly pour water to top of the container. Avoid over flow during pouring water;
- Replace the lid;
- The filtered water will be collected in the lower container (storage unit);
- Turn on faucet and collect water in a clean glass;
- After collecting water, turn off the faucet, drink _____, wash the glass and put in a clean place.

4.1.2. Maintenance procedures:

- Wash hands with soap water before operating and maintaining the filter;
- The filter and location in & around filter should be always clean. Protect from outer contamination and access to animals;
- Always check for seepage and cracks. Since SBL CSF container is made up of clay, seepage of water around the container is normal. It may stop few days after operation of the filter. However, if the seepage occurs for long time after the installation (one month), the container should be replaced. Likewise, if the cracks are observed in the filter body, the container should be replaced;
- The flow rate of CSF may be reduced after few days of filter operation. This occurs due to clogging of filter disc. In such case, filter disc should be cleaned thoroughly and gently by the brush provided with filter set;
- Never boil the filter disc and never use soap to clean/wash the filter disc;
- Filter faucet should not to touched by dirty hands;
- If water is too turbid, it is recommended to screen water through clean cloth & let it settle for sometime then the water can be poured in the filter vessel;
- The vessels for collecting filtered water such as glass and bucket should be always clean. The bucket should always be well covered.

4.2. O&M of Large CSF:

4.2.1. Operation procedures:

Following are the operation procedures of large CSF:

- Open the lid from top container and pour water onto the diffuser basin;
- Avoid over flowing while pouring the water;
- The filtered water will be collected in the lower container;
- Turn on faucet and collect water in a clean glass;
- After collecting drinking water, turn off the faucet, wash the glass and put in a clean place.
- The filtered water can also be collected in a clean bucket which can be placed in every class room. Try to avoid multiple level uses. Use of bucket/vessel with small and narrow mouth with taps is recommended so that there will be less chance of recontamination.

4.2.2. Maintenance procedures:

- Wash hands with soap water before operating and maintaining the filter;
- The filter and location in & around filter should be always clean. Protect from outer contamination and access to animals;
- The flow rate of CSF may be reduced after few days weeks of filter operation. This occurs due to clogging in filter candles. In such case, filter candles should be carefully removed from the bucket, cleaned thoroughly and gently by soft tooth brush. The cleaned candles should be re-fixed tightly to the bucket;
- Never boil the filter candles and never use soap to clean/wash;
- Filter faucet should not be touched by dirty hand;
- If water is too turbid, it is recommended to screen water through clean cloth & let it settle for sometime then the water can be poured in the filter vessel;
- In case of leakage from pipe joints and taps, tie them securely. Replace the parts if leakage still persists;
- The inner part of both containers should be observed from time to time. Clean them regularly as per requirement;
- The vessels for collecting filtered water such as glass and bucket should be always clean. The bucket should always be well covered.

4.3. O&M of BSF:

4.3.1. Operation procedures :

For proper use of BSF, either direct attachment of water supply or an electrical water pump is required to pump water into the BSF. A shed can be built to keep filtered water cool. Following are the operation procedures of BSF:

- Open the lid from top container and place the pipe connected to water pump;
- Run a water pump to pour water at the top container;
- Watch carefully if water is full tank. Avoid over flowing;
- The filtered water will be collected in the storage unit;
- Turn on faucet and collect water in a clean glass;
- After drinking water, turn off the faucet, wash the glass and put in a clean place.
- The water can be collected in a clean bucket which can be placed in every class rooms.

4.3.2. Maintenance procedures :

- Wash hands with soap water before operating and maintaining the filter;
- The filter and location in & around filter should be always clean. Avoid from outer contamination and access to animals;
- The flow rate of BSF may be reduced after few weeks of filter operation. This occurs due to clogging of top layer of fine sand. Following are the steps to clean the BSF:
 - i. Remove the lid and diffuser basin from the filtration unit;
 - ii. Slowly scratch the upper layer of sand;
 - iii. The resting water level will turn turbid by scratching the sand layer;
 - iv. Turn on a gate valve and flush the turbid water;
 - v. Turn off the gate valve, put the diffuser basin and fill about 10 cm of water above fine sand layer;
 - vi. Repeat the process for two more times;
 - vii. Then the filter can be operated again;

viii. Clean the filter only if flow rate is too low i.e. if the filter is providing sufficient water against the water demand.

- Filter faucet should not be touched by dirty hands;
- Check for leakages from pipe joints and taps. Fix them securely and replace the parts if needed;
- Observe the inner part of collection tank and clean it if it is dirty;
- The storage tank should always be well covered;
- Regularly clean platform and drainage;
- The filtered water collecting vessels such as glass and bucket should be always clean. The bucket should always be well covered;
- Water pump should be also maintained regularly. Small spare parts of water pump can be purchased in advance for replacing during the maintenance.
- In case of BSF with arsenic removal system, after few months of operation the iron nails in a diffuser basin will turn into one single mass/block. This will cause clogging of diffuser basin. In such case, remove iron nails from diffuser basin, break apart the block, wash iron nails thoroughly, clean the diffuser basin and put the individual nails back into the basin. The clogging problem will be solved.

4.4. O&M of SODIS:

4.4.1. Operation procedures :

SODIS requires clean, transparent 1-2 liter bottles without cracks or scratches, and clean roof or metal/wooden stand to expose the bottles at the sun. Following are the steps of SODIS method:

- Wash the bottle clean together with its cap before use
- Fill the bottle fully and close the lid tightly
- Expose the bottle in inclined position for about 7-8 hours in sunny days and 2 days during cloudy days
- The water is safe for drinking

4.4.2. Maintenance procedures :

- The place for exposing SODIS bottles (roof, metal/wooden stand) should be always clean;

- Always make sure that the bottle is transparent and is always full of water;
- Always remove label of the bottle;
- In case of turbid water, it should be filtered before doing SODIS;
- SODIS bottle should be always exposed inclined at least 7-8 hours to the sun light;
- Generally, PET bottles can be used for 6 months. However, if the bottle surface is scratched or rough, then replace with new bottles;
- Algae (green particles) may form inside the bottle over time. It can be cleaned by using a stick wrapped with clean cloth. Water mixed with some rice grains or crushed egg shells can also remove algae from the bottle;

4.5. O&M of Chlorination:

4.5.1. Operation procedures :

There should be a water tank at school to do chlorination. The volume of the water tank should be calculated before adding chlorine solution in the water. Following are the operation procedures for chlorination method:

- Calculate the volume of water tank (see section 4.4 for calculation);
- According to the volume of tank prepare required amount of chlorine solution (see section 4.4 for the details);
- Add the chlorine solution in the tank. Make sure that all taps are closed during this process;
- Avoid direct contact with chlorine solution. In case of direct contact with skin, immediately rinse with plenty of water. If skin irritation exists contact near by health center;
- Test Free Residual Chlorine (FRC) after 30 minutes of adding the chlorine solution. FRC should be between 0.2 -0.5 mg/L. If FRC is more than this limit, let the tank open for another 30 minutes and test FRC again. Repeat the process till FRC is found within the limit of 0.2-0.5 mg/L. If added chlorine solution is less amount then the FRC test result shows less than 0.2 mg/L. Hence, correct measurement and dosing of chlorine solution is very crucial for avoiding such consequences;
- If FRC test result shows between 0.2-0.5 mg/L, the water is safe for drinking.

4.5.2. Maintenance procedures :

- The water tank should be always clean. If it is dirty i.e. contains dirt or debris , clean it properly before adding chlorine solution
- A jar filled with chlorine solution should be kept in a dark place and away from the children;
- Always store bleaching powder in a air tight package and place it in a dark place;
- Since chlorine is a chemical, it should be handled with care. Avoid direct contact with chlorine solution. In case of direct contact with skin, immediately rinse with plenty of water. If skin irritation exists contact near by health center;
- Check for leakages from tank taps. Fix the leakages and replace the parts if needed;
- Always keep drainage and platform clean.

4.6. O&M requirements:

Some of the key O&M requirements including responsible person/group is presented below in the table:

POU technologies	O&M requirements	Who is responsible?
CS Filter	Pouring water onto the filter	School teacher/designated students/care taker
	Observing damage or leakage	School teacher/designated students/care taker
	Cleaning the filter	Designate students/ Care taker
	Fixing the leakage, repairing filter stand	Care taker
	Replacing filter body, candles, tap and pipe fittings	WSSDO Technician
Large CSF	Pouring water onto the filter	School teacher/designated students/care taker
	Observing damage or leakage	School teacher/designated students/care taker
	Cleaning the filter	Designate students/ Care taker
	Fixing the leakage, repairing filter stand	Care taker

POU technologies	O&M requirements	Who is responsible?
	Replacing filter body, candles, tap and pipe fittings	WSSDO Technician
Biosand Filter	Pouring or pumping water onto the filter	Care taker
	Observing damage or leakage	School teacher/designated students/care taker
	Fixing the leakage	Care taker
	Cleaning the filter	Care taker
	Keeping surrounding of the filter neat and clean	School teacher/designated students/care taker
	Replacing or adding fine sand if needed	WSSDO technician
	Replacing pipes and its fittings	WSSDO technician
	Repairing water pump	Water pump technician
SODIS	Placing SODIS bottles in the sun	School teacher/designated students/care taker
	Taking SODIS bottles to the class	Students/Care taker
	Bringing SODIS bottles and stand in the office after school hour	Designated students/care taker
	Replacing bottles	Care taker
	Repairing stand	Care taker
Chlorination	Adding chlorine solution into the tank	Trained school teacher/care taker
	Testing FRC before letting student drink chlorinated water	Trained school teacher
	Cleaning the water tank	Care taker

ANNEX

ANNEX: 1 – Initial assessment form

District:	VDC/Municipality
Ward No:	Tole:
Name of school:	Level:

A. Basic School Information

Number of students:	Male:
	Female:
Number of teachers:	Number of staff:
	Type of staff:
Number of school blocks:	Number of classes:
Number of students/class:	
Distance from main road:	
Type of road to reach school:	

B. Technical

Main source of drinking water:	Is the source inside school premises?	
	Yes	No (If no where?)
Distance of water from school (in meters):		
Toilets available:	Yes	No
Number of toilets for:	Girl	Boys

Type of sanitation facility:

Latrine

Urinal

Distance of toilet from water source:

Are there any water storage facilities?

Yes No

If yes, provide details of storage facilities

Covered Concrete tank

Covered Plastic tank

Open tank

Is there any water treatment facility currently in operation in the school? Does the school currently do anything to make the water safer to drink?

Yes No

If yes, what?

Do drinking water sources provide adequate quantities of drinking water for students and staffs?

Yes No

If no, what other source do they use to fulfill demand?

Does the source fulfill the demand through out the year? Do the sources?

Yes No

Is there sufficient space in the school to install POU facilities?

Classes:

Open space/school compound:

Is the space protected or need to be protected?

Involvement of the school in water and sanitation activities

What types of child clubs are active?

Get the following activities:

Club	Focus/regular activities	Members	Class

Have they been able to influence other students in convincing practices such as hand washing/ use of toilets or any other?

Is there a parents- teachers association in the school? Y N

Does it meet regularly? Y N

Frequency of meetings:

What are their regular activities; and their contribution to the school?

Is there a school management system? Y N

Function of school management committee

Has the school or PTA made any contribution related to school development activities? (School building, education materials, toilets etc.) Describe:

What was the contribution mechanism in these initiatives?

Cost sharing mechanism with partners if any:

Don't ask. To be filled by interviewer:

Is the school ready for POU installation? Y N

If no, what needs to be done to make it ready?

Water Quality Results:

Parameters	Unit	Result	Remarks (if any)
Bacteria	cfu/100 ml		
Iron	mg/L		
Turbidity	NTU		
Arsenic	ppb		

(Name)

(Date)

(Signature)

ANNEX: 2 – Monitoring checklist

1. Regular CSF:

Name of school:	
Address:	
Date of installation:	
Responsible for maintenance:	

A. Monitoring checklist:-

Things to observe	Yes	No
Is filter in regular operation?		
Any cracks or seepage in filter body?		
Is the stand stable and secure?		
Does filter has lid?		
Use clean safe water storage?		
Is sanitary condition in and around filter good?		
Is filter being cleaned regularly?		
Is treated water sufficient for all?		

B. Overall observation:

--

C. Maintenance done/suggested – if any:

--

(Name)

(Date)

(Signature)

2. Large CSF:

Name of school:	
Address:	
Date of installation:	
Responsible for maintenance:	

A. Monitoring checklist:-

Things to observe	Yes	No
Is filter in regular operation?		
Is the stand stable and secure?		
Does filter has lid?		
Use clean safe water storage?		
Is sanitary condition in and around filter good?		
Is filter being cleaned regularly?		
Any leakages from pipe fittings and taps?		
Is water pump in good condition?		
Is treated water sufficient for all?		

B. Overall observation:

C. Problems observed – if any:

D. Maintenance done – if any:

E. Maintenance suggested – if any:

(Name)

(Date)

(Signature)

3. BSF:

Name of school:	
Address:	
Date of installation:	
Responsible for maintenance:	

A. Monitoring checklist:-

Things to observe	Yes	No
Is filter in regular operation?		
Is the stand stable and secure?		
Does filter has lid?		
Is sanitary condition of storage tank good?		
Is sanitary condition in and around filter good?		
Is filter being cleaned regularly?		
Any leakages from pipe fittings and taps?		
Is water pump in good condition?		
Proper water level above fine sand?		
Diffuser basin in place?		
Iron nails and brick chips in place? (in case of arsenic removal system only)		
Is treated water sufficient for all?		
Is platform and drainage clean?		

B. Overall observation:

C. Problems observed – if any:

D. Maintenance done – if any:

E. Maintenance suggested – if any:

(Name)

(Date)

(Signature)

4. SODIS:

Name of school:	
Address:	
Date of installation:	
Responsible for maintenance:	

A. Monitoring checklist:-

Things to observe	Yes	No
Is bottle placed/exposed in right place?		
Is roof or stand clean? sanitary condition of place good?		
Bottles full of water?		
Lid securely closed?		
Using transparent bottles?		
Bottles without labels, cracks and scratches?		
Using correct size (diameter) of bottles?		
Difficult to find bottles?		
Is treated water sufficient for all?		

B. Overall observation:

C. Problems observed – if any:

D. Maintenance done – if any:

E. Maintenance suggested – if any:

(Name)

(Date)

(Signature)

5. Chlorination:

Name of school:	
Address:	
Date of installation:	
Responsible for maintenance:	

A. Monitoring checklist:-

Things to observe	Yes	No
Is the water tank clean?		
Using correct chlorine dose? (ask the operator)		
Storing bleaching powder and chlorine solution in correct place?		
Test FRC after adding chlorine solution?		
Drink water after 30 minutes of adding chlorine?		
Clean water tank regularly?		
Bad smell of chlorine?		
Water sufficient for all?		
Difficult to calculate chlorine dose?		

B. Overall observation:

C. Problems observed – if any:

D. Maintenance done – if any:

E. Maintenance suggested – if any:

(Name)

(Date)

(Signature)